



NEW TECH SCIENTIFIC

As the globalized world forces us today to face planetary health emergencies, human instinct of adaptation prevents us from remaining unprepared and vulnerable.

This is the reason why we have combined a practical and modular nebulization system with the action of **BIOAKT**, the only broad-spectrum bactericidal viricidal and fungicidal disinfectant, non-toxic and biocompatible.

We present **GATEAKT**: the solution for sanitizing environments where the flow of people increases the risk of contamination.

GATEAKT

A door
towards safety

Modular
solution for
sanitizing users
and public
environments



This document does not constitute a contractual specification
New Tech Scientific reserves the right to modify the technical characteristics of the system presented without notice



NEW TECH SCIENTIFIC



NEW TECH SCIENTIFIC

GATEAKT

Modular
solution
for sanitization
made in Italy

SANITIZING AGENT

BIOAKT is a broad-spectrum disinfectant, viricidal and fungicidal bactericide, classified as a Class IIb medical device.

Composed of silver ions stabilized in citric acid, these act as a food source for microbes and, by reacting with them, cause irreversible damages by blocking their metabolic and reproductive functions thus causing their death.

BIOAKT is unique for its certified biocompatibility, non-toxicity and efficacy, along with bacterial and viral load reduction times in the order of the minute and a residual protection of over 18 hours.

- NON-TOXIC
- NOT CAUSTIC
- COLORLESS
- ODORLESS



BIOAKT is an exclusive of the New Tech Scientific company founded by NEW TECH SOLUTIONS and TEKNE.



This document does not constitute a contractual specification
New Tech Scientific reserves the right to modify the technical characteristics of the system presented without notice

Specifications

CE Class IIb medical device
(Directive 93/42/EEC and as amended)

- > total non-toxicity and high efficacy
- > bacterial and viral load reduction times of about 60 seconds with residual protection over 18 hours



GATEAKT

Modular
solution
for sanitization
made in Italy

We create gates to sanitize users who access commercial, public and workplace spaces.

Responding to the different needs related to the number of daily accesses, we have designed a basic module for quick installation (no specialized technicians are required) that can be easily connected to other modules, if necessary, in order to expand the atomization surface and consequently the frequency entrance to the GATE.

GATEAKT is suitable for high flows of people at the entrance. Each GATEAKT includes a tunnel and a control unit.

CONTROL UNIT

Pumping system, electronic control unit and sanitizing tank are installed inside a small dimensions box, which can be set and remotely controlled up to 20m from the tunnel and hidden in a suitable place: the connection with the tunnel is made through a pseudotube holding sanitizing liquid and control wiring.

TUNNEL

In the light-alloy internal structure of the module, electronically-activated nozzles system diffuses sanitizer aerosol when a person passes through the tunnel by means of a movement sensor. The system, driven by a control unit designed by New Tech Scientific, distributes sufficient quantities of liquid for each access.

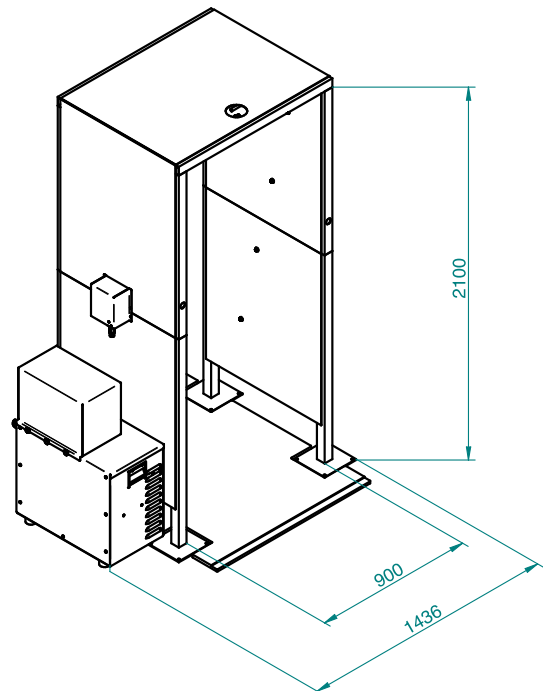

TEMPERATURE CONTROL

At the entrance to the tunnel an easy-to-use temperature detection system is installed: the hand is brought close to the contactless detector and an infrared sensor measures the body temperature with an error of ± 0.3 ° C. An acoustic and visual alarm confirms the detection, in green if it is in the allowed range, in red if not. On the side of the detector (in a position not visible to the person entering the gate) there is a small display for the exclusive use of the surveillance staff to check the temperature read.





GATEAKT

**Modular
solution
for sanitization
made in Italy**

MISTING SYSTEM

The sanitizing liquid is reduced into very fine drops (from 5 to 15 µm) thanks to dedicated nozzles powered by a high pressure pump within the control unit. In this way the nebulization process is very fast and takes place before the sanitizing liquid falls to the ground. The nozzles are anti-drop, made of brass and / or stainless steel.

The number of nozzles varies according to the configuration chosen based on the flow of users expected in the tunnel.

NOZZLES	Liquid Q.ty	Flow
9	4ml/person	720 pers./h

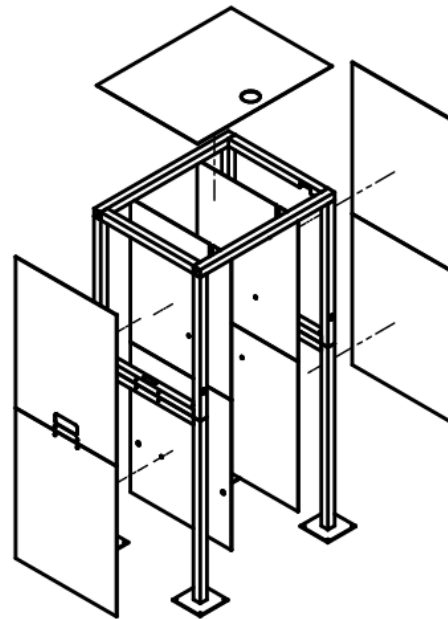

SANITIZING MAT

Made with a special material, it has the characteristic of being non-rotting, it does not get wet but it keeps the sanitizing liquid on its surface. In this way also the soles of the passers-by are sanitized, avoiding diffusion of pathogens in the environment.

CUSTOMIZATION

The external finish, made of PONZIO BOND® is customizable with images, texts or logos, depending on customer requests. (OPTIONAL)

WHY CHOOSE GATEAKT

Because it is a complete, ready to use system, easy to assemble and maintain, designed for different access flows, *the only one equipped with a biocompatible sanitizer, certified and effective and therefore able to guarantee complete sanitation of your environment.*

No danger of toxicity, no unpleasant smell or excessive traces of humidity: an accurate purification and a pleasant sense of freshness.

For your own safety, for the safety of your employees and your customers.

This document does not constitute a contractual specification
New Tech Scientific reserves the right to modify the technical characteristics of the system presented without notice

